

Rolling Pin

SVPC-RP-P5982PP03

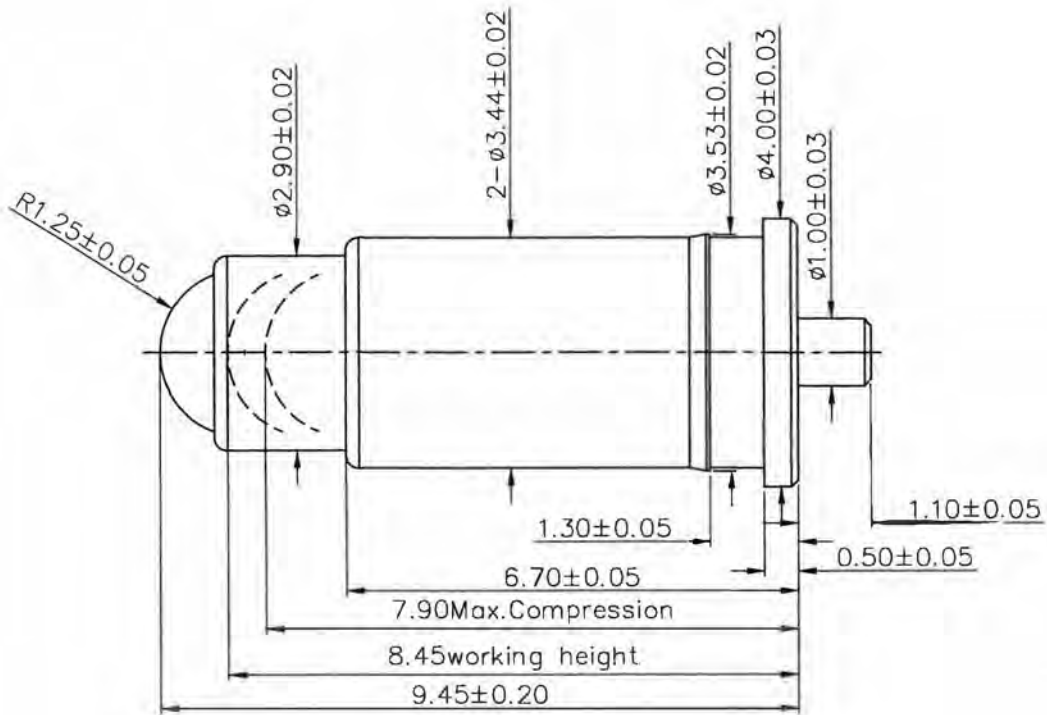

Dimension: mm

NOTE:

1. Material

Plunger: Brass
 Barrel: Brass
 Spring: SUS
 Ball: Brass

2. Plating

Plunger&Barrel: 15 microinch Min. Au over 50 ~ 100 microinch Min. Ni
 Ball: 5 microinch Min. Pd over 30 microinch Min. PdNi over 40 ~ 80 microinch Min. Ni

3. Electrical

Rated current & voltage: DC 12V; 1 A Max.
 Contact resistance: 100 mohm Maximum at working height (quiescence)

4. Mechanical

Spring force: 80g±20g at working height.
 Durability: min. 5,000 circles

5. To ensure the best usage, please operate it based on the working height.

6. When the current is greater than 1 A then need to increase the time delay circuit (3 second)