

# Rolling Pin

## SVPC-RP-P5982PP02

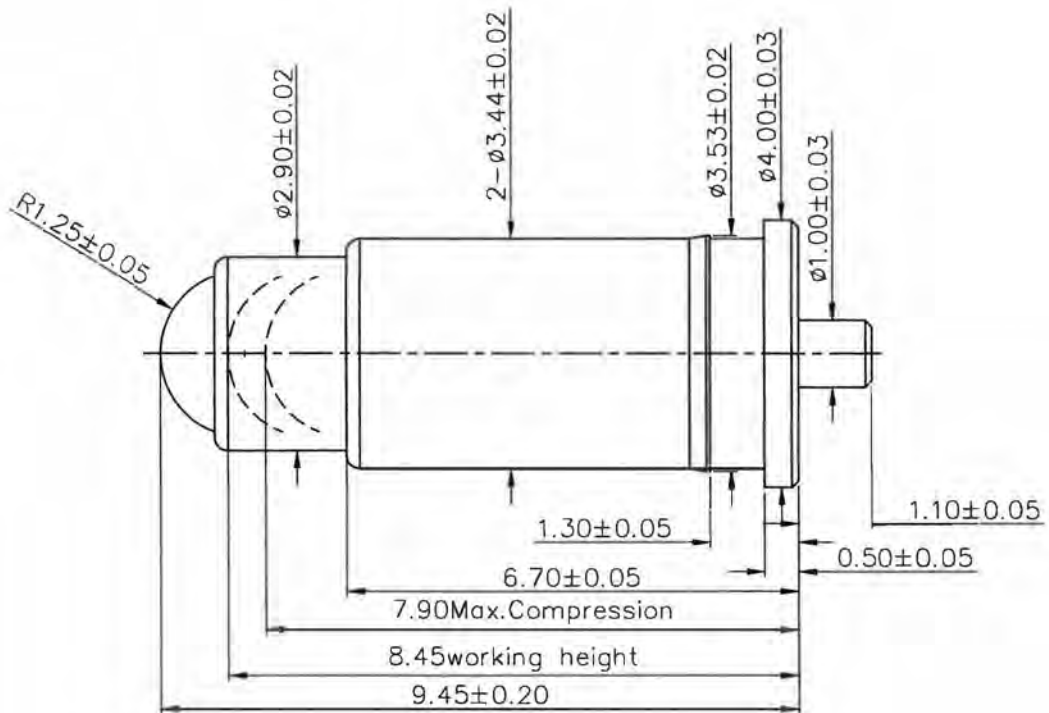

Dimension: mm

**NOTE:**

**1. Material**

Plunger: Brass  
 Barrel: Brass  
 Spring: SUS  
 Ball: Brass

**2. Plating**

Plunger & Barrel: 15 microinch Min. Au over 50 ~ 100 microinch Min. Ni  
 Ball: 5 microinch Min. Pd over 30 microinch Min. PdNi over 40 ~ 80 microinch Min. Ni

**3. Electrical**

Rated current & voltage: DC 12V; 1 A Max.  
 Contact resistance: 100 mohm Maximum at working height (quiescence)

**4. Mechanical**

Spring force: 60g±15g at working height.  
 Durability: min. 5,000 circles

5. To ensure the best usage, please operate it based on the working height.

6. When the current is greater than 1 A then need to increase the time delay circuit (3 second)