

Please Approve this Drawing

Date	
Signature	

REVISIONS (修正)			
NO. (序号)	DESCRIPTION(描述)	DCN NO.(变更号)	DATE(日期)
D.0	NEW RELEASE		2018.11.13

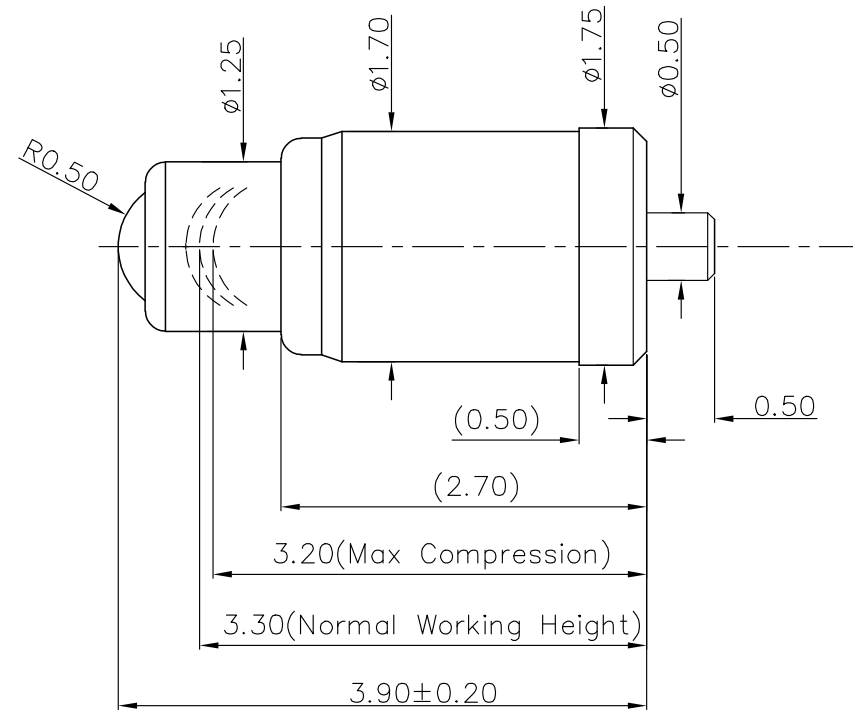

- NOTE;
- Material  
Plunger: brass  
Barrel: brass  
Spring: SUS  
Ball: SUS
  - Plating  
Plunger&Barrel: 10 micro-inch minimum Au over 50~120 micro-inch nickel  
Ball: 15 micro-inch minimum Pd over 15 micro-inch minimum PdNi over 40~80 microinch Ni
  - Electrical  
Rated current & voltage: DC12V; 1A.  
Contact resistance: 300 mohm maximum at working height(quiescence)
  - Mechanical  
Spring force: 60±15g at Normal working height  
Durability: 10,000 cycles(minimum)(for compress)
  - To ensure the best usage, please operate it based on the working height  
Based on the engineering drawings, shall not exceed the maximum allowed compression
  - When the current is greater than 1A then need to increase the time delay circuit(3 second)
  - RoHS & HF complied product.

DRAW (设计)	彭世变	SCALE (比例)	20 : 1	UNIT (单位)	mm	DRAWING NO. (图号)	P5079PP08
COUNTER SIGN (会签)		SHEET (页数)	1 of 1	PROJECT (视图)		MATERIAL (材质)	Seeing notes (见备注)
AUDIT (审核)		DATE (日期)	2018.11.13	VER (版次)	D.0	TITLE (品名)	Pogo pin
APPROVE (核准)		PLATE (镀层)	Seeing notes(见备注)				
THE UNMARKED TOLERANCE ARE AS BELOW : (未标记的公差)				<b>N&amp;H Technology GmbH</b> <b>SVPC-RP-P5079PP08</b>			
LENGTH (尺寸)		ANGLE (角度)					
0~6.0	±0.05mm	0.	±2.0°				
>6~30	±0.10mm	0.0	±1.0°				
>30~120	±0.15mm	0.00	±0.50°				