

Rolling Pin

SVPC-RP-P07562PP1

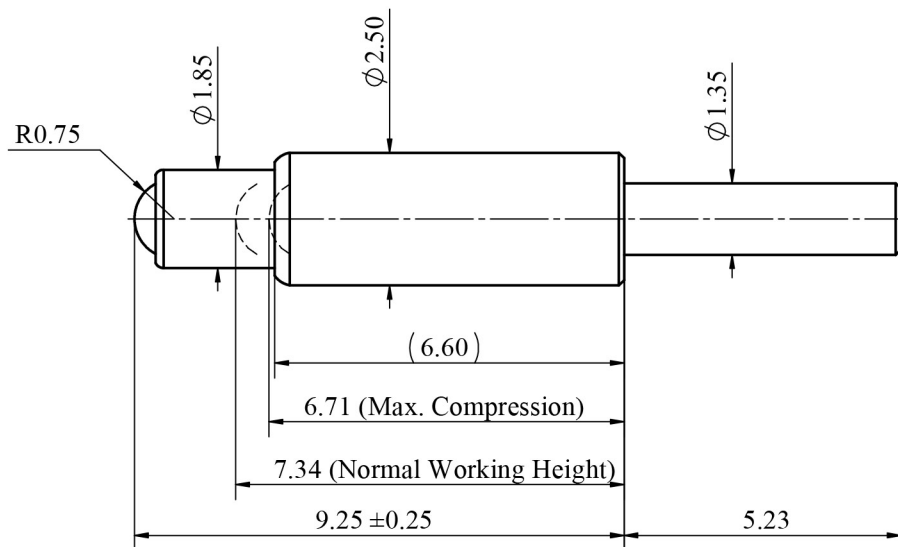

Dimension: mm

NOTE:

1. Material

Plunger: Brass

Barrel: Brass

Spring: SUS

Ball: Brass

2. Plating

Plunger & Barrel: 10 microinch min. Au over 50 ~ 120 microinch min. Nickel

Ball: 5 microinch min. Pd over 30 microinch Min. PdNi over 40 ~ 80 microinch min. Ni

3. Electrical

Rated current & voltage: DC 12V; 3A

Contact resistance: 100 mohm Maximum at working height (quiescence)

4. Mechanical

Spring force: 90g ± 20g at working height.

Durability: min. 10,000 circles

5. To ensure the best usage, please operate it based on the working height.

Based on the engineering drawings, shall not exceed the maximum allowed compression

6. RoHS & HF complied product