

# Rolling Pin

## SVPC-RP-P07393PH1

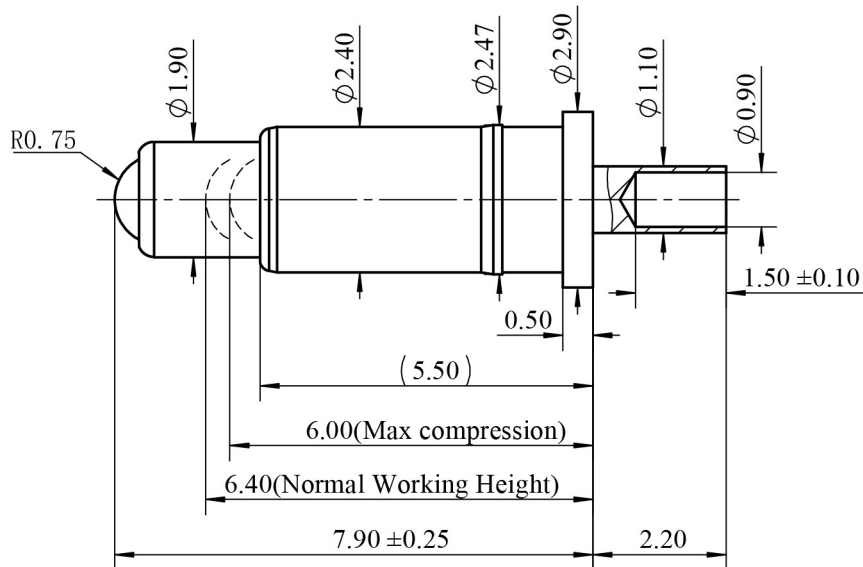

Dimension: mm

**NOTE:**
**1. Material**

Plunger: Brass  
 Barrel: Brass  
 Spring: SUS  
 Ball: Brass

**2. Plating**

Plunger & Barrel: 10 micro-inch min. Au over 50 ~ 120 micro-inch min. Nickel  
 Ball: 5 micro-inch min. Pd over 30 micro-inch min. PdNi over 40 ~ 80 micro-inch min. Ni

**3. Electrical**

Rated current & voltage: DC 12V; 2A  
 Contact resistance: 100 mohm Maximum at working height (quiescence)

**4. Mechanical**

Spring force:  $90g \pm 20g$  at working height.  
 Durability: min. 10,000 circles

5. To ensure the best usage, please operate it based on the working height.  
 Based on the engineering drawing, shall not exceed the maximum allowed compression.

6. RoHS & HF complied product