

Rolling Pin

SVPC-RF-P5079FP04

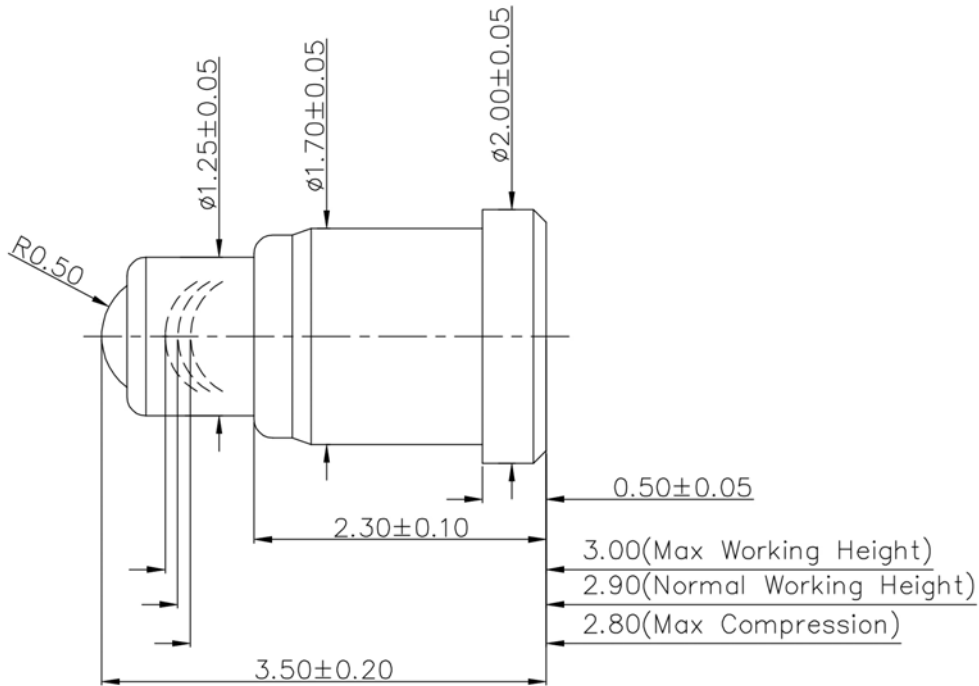

Dimension: mm

NOTE:

1. Material

Plunger: Brass

Barrel: Brass

Spring: SUS

Ball: Brass

2. Plating

Plunger & Barrel: 10 microinch Min. Au over 50 ~ 120 microinch Min. Ni

Ball: 15 microinch Min. Pd over 15 microinch Min. PdNi over 40 ~ 80 microinch Min. Ni

3. Electrical

Rated current & voltage: DC 12V; 2A Max.

Contact resistance: 100 mohm Maximum at working height (quiescence)

4. Mechanical

Spring force: 60g ± 15g at working height.

Durability: min. 2,000 circles

5. To ensure the best usage, please operate it based on the working height.

6. When the current is greater than 1 A then need to increase the time delay circuit (3 second)