

# NTC325 Series

## Features

■ Lead Free ■ HF ■ RoHS

- Horizontal direction.

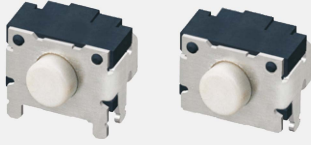

Rating (max)	DC12V 50mA
Contact Resistance	500mΩ max.
Insulation Resistance	DC500V-100MΩ min.
Withstand Voltage	AC250V - 1 minute
Stroke	0.2±0.1mm
Operating Force	160±50gf

### Recommended Reflow Soldering Profile

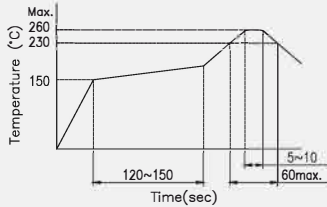

Number of Reflow Pass : 2 cycles

### Recommended Manual Soldering Profile

	Temperature	Time
Manual Soldering Temperature	350 °C (max.)	3 Sec.(max.)

The solder iron and solder shall be applied at a distance of 1.91 mm to 2.54 mm from the plastic housing.

Durability 100,000 cycles

### ■ SMT- J Type Horizontal 3.55L x 4.5W x 3.3H

Product No.	Package
NTC325-DT1J-A160T	1,800 Pcs/Reel

#### Schematic

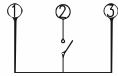

#### P.C.B Layout

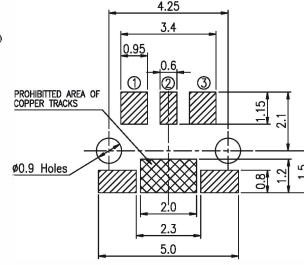

### ■ Outline Drawing

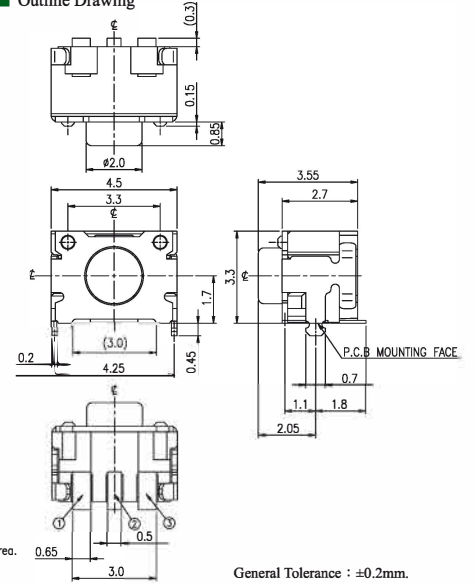

General Tolerance : ±0.2mm.

### ■ SMT- J Type Horizontal 3.55L x 4.5W x 3.3H

Product No.	Package
NTC325-ET1J-A160T	1,800 Pcs/Reel

#### Schematic

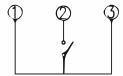

#### P.C.B Layout

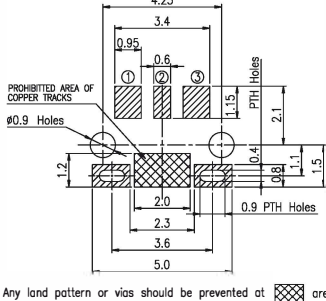

### ■ Outline Drawing

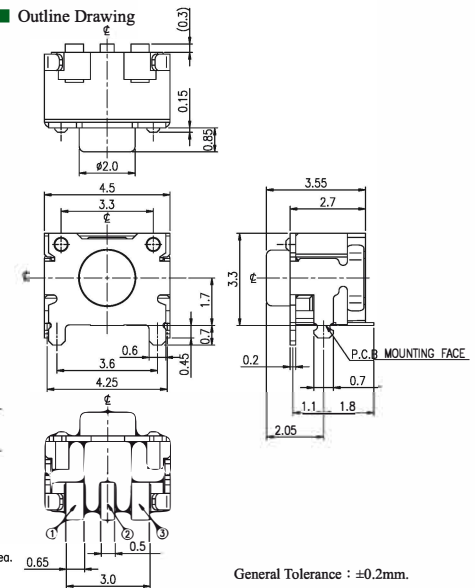

General Tolerance : ±0.2mm.