

NTC313 Series

■ Features

■ Lead Free ■ HF ■ RoHS

- Horizontal direction.



Rating (max)	DC12V 50mA
Contact Resistance	1Ω max.
Insulation Resistance	DC500V-100MΩ min.
Withstand Voltage	AC250V - 1 minute
Stroke	0.15±0.1 mm
Operating Force	160±50gf

Recommended Reflow Soldering Profile

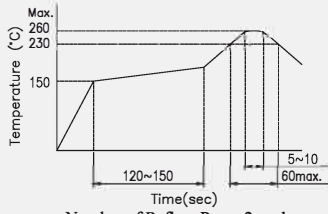

Recommended Manual Soldering Profile

	Temperature	Time
Manual Soldering Temperature	350 °C (max.)	3 Sec. (max.)

The solder iron and solder shall be applied at a distance of 1.91 mm to 2.54 mm from the plastic housing.

Durability 200,000 cycles

■ SMT- G Type Horizontal 4.8L x 2.6W x 2.9 H

Product No.	Package
NTC313-AA1G-A160T	2,200 Pcs/Reel

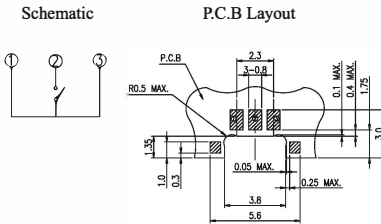

■ Outline Drawing

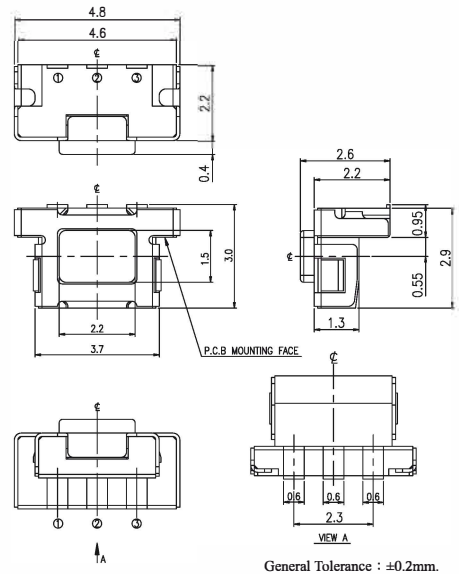

■ SMT- G Type Horizontal 4.8L x 2.6W x 2.9 H

Product No.	Package
NTC313-BA1G-A160T	2,200 Pcs/Reel

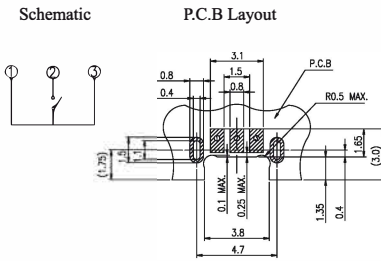

■ Outline Drawing

