

NTC019 Series

■ Features

■ Lead Free ■ HF ■ RoHS

- Just two terminal.

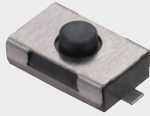

Rating (max)	DC12V 50mA
Contact Resistance	100mΩ max.
Insulation Resistance	DC500V-100MΩ min.
Withstand Voltage	AC250V - 1 minute

Recommended Reflow Soldering Profile

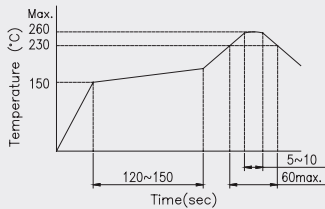

Recommended Manual Soldering Profile

	Temperature	Time
Manual Soldering Temperature	350 °C (max.)	3 Sec.(max.)

The solder iron and solder shall be applied at a distance of 1.91 mm to 2.54 mm from the plastic housing.

■ SMT-G Type Vertical 6.0L x 3.8W x 2.5H

■ Outline Drawing

Stroke $0.25 \pm 0.1\text{mm}$

Product No.	Force	Durability	Package
NTC019-CT1G-C160T	160±50gf	50,000 cycles	3,000 Pcs/Reel
NTC019-CT1G-C260T	260±70gf	30,000 cycles	

Schematic

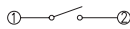

P.C.B Layout

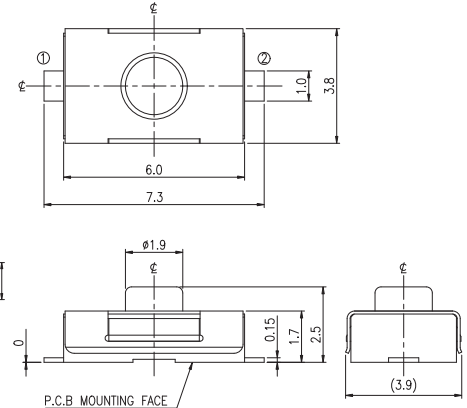
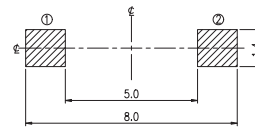

General Tolerance : ±0.2mm.

■ SMT-J Type Vertical 6.0L x 3.8W x 2.5H

■ Outline Drawing

Stroke $0.25 \pm 0.1\text{mm}$

Product No.	Force	Durability	Package
NTC019-CT1J-C160T	160±50gf	50,000 cycles	3,000 Pcs/Reel
NTC019-CT1J-C260T	260±70gf	30,000 cycles	

Schematic

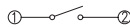

P.C.B Layout

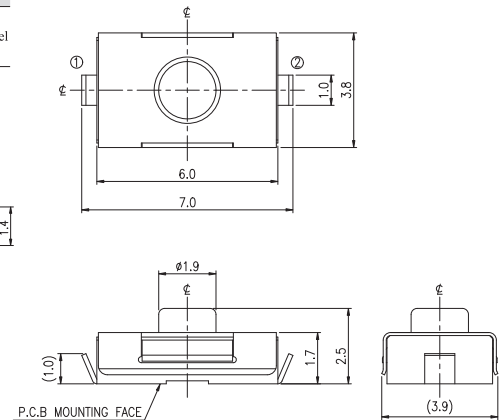
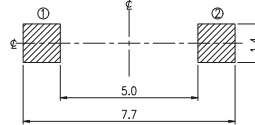

General Tolerance : ±0.2mm.