

# NSS602 Series

■ Features

■ Lead Free ■ HF ■ RoHS

- Auto return type.
- Low profile H:1.35mm.

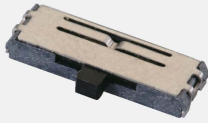

Rating	DC15V 0.3A
Stroke	1.5 ± 0.15 mm
Contact Resistance	1Ω max.
Insulation Resistance	DC250V - 10MΩ min.
Withstand Voltage	AC100V - 1 minute

Recommended Reflow Soldering Profile

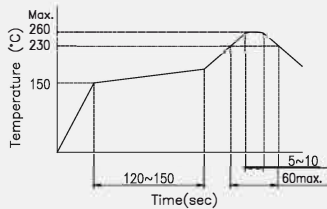

Number of Reflow Pass : 2 cycles

Recommended Manual Soldering Profile

	Temperature	Time
Manual Soldering Temperature	350 °C (max.)	3 Sec. (max.)

The solder iron and solder shall be applied at a distance of 1.91 mm to 2.54 mm from the plastic housing.

Durability 5,000 cycles

■ SMT - J Type Horizontal 9.8L x 3.0W x 1.35H  
1Pole 3Positions

Product No.	Package
NSS602-213N-AAAJIT	3,000 Pcs/Reel

■ Specifications

Timing	Non-Shorting
Operating Force	A→B : 100 <sup>+80</sup> gf B→A : 150±100 gf B→C : 150±100 gf

Schematic

P.C.B Layout

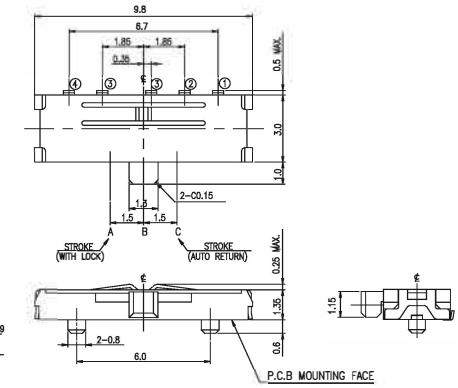
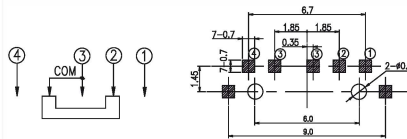

General Tolerance : ±0.2mm.