

# NSS504 Series

## Features

- Non shorting.
- Tall height.



Timing	Non-Shorting
Insulation Resistance	DC500V -100MΩ min.
Withstand Voltage	AC500V - 1 minute

### Recommended Reflow Soldering Profile

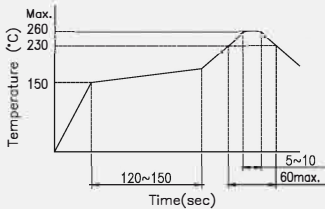

### Recommended Wave Soldering Profile

Parameters	Lead-Free Specification
Preheating Time	60 sec max.
Preheating Temperature	100°C max.
Continuous Dipping Time	3~5 sec max.
Soldering Temperature	260°C max.

### Recommended Manual Soldering Profile

Manual Soldering Temperature	Temperature	Time
	350 °C (max.)	3 Sec.(max.)

The solder iron and solder shall be applied at a distance of 1.91 mm to 2.54 mm from the plastic housing.

Durability 10,000 cycles

## DIP - D Type Vertical 1 Pole 3 Positions 13.0L x 3.5W x 3.5H

Product No.	Package
NSS504-213N-AAGD1B	Bulk

### Specifications

Rating	DC6V 0.3A
Strok	2.0±0.3 mm
Operating Force	A→B, C→B : 200 ± 100 gf B→A, B→C : 250 ± 150 gf
Contact Resistance	70mΩ max

### Schematic

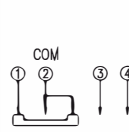

### P.C.B Layout

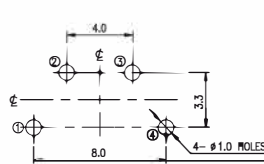

### Outline Drawing

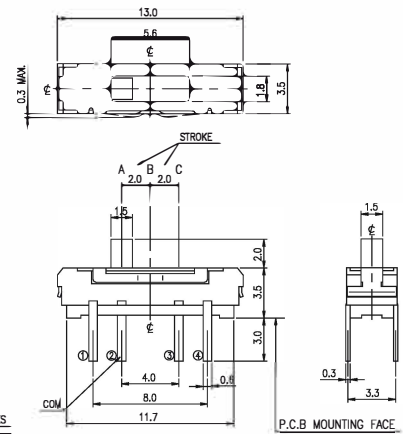

General Tolerance : ±0.2mm.

## DIP - D Type Vertical 2 Poles 3 Positions 13.0L x 3.5W x 3.5H

Product No.	Package
NSS504-223N-AACD1B	Bulk

### Specifications

Rating	DC6V 0.3A
Strok	2.0±0.3 mm
Operating Force	A→B, C→B : 200 ± 100 gf B→A, B→C : 250 ± 150 gf
Contact Resistance	70mΩ max

### Schematic

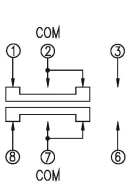

### P.C.B Layout

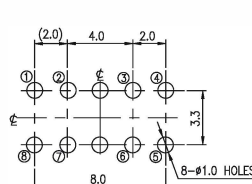

### Outline Drawing

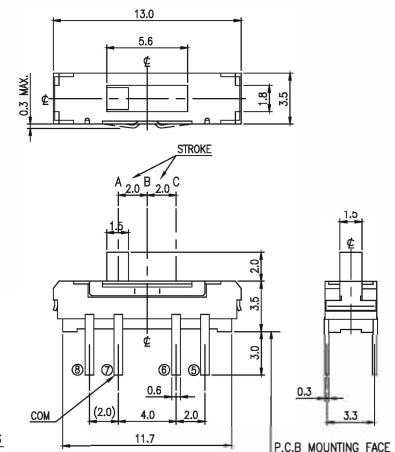

General Tolerance : ±0.2mm.

## SMT - G Type Vertical 1 Pole 3 Positions 13.0L x 3.5W x 3.5H

Product No.	Package
NSS504-213N-AAGG1T	900 Pcs/Reel

### Specifications

Rating	DC6V 0.3A
Strok	2.0±0.3 mm
Operating Force	A→B, C→B : 200 ± 100 gf B→A, B→C : 250 ± 150 gf
Contact Resistance	70mΩ max

### Schematic

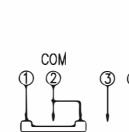

### P.C.B Layout

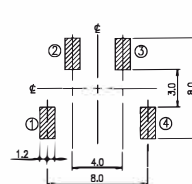

### Outline Drawing

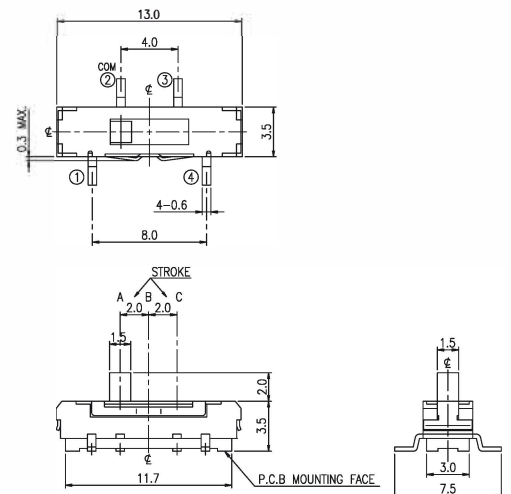

General Tolerance : ±0.2mm.

# NSS504 Series

■ Lead Free ■ HF ■ RoHS

■ SMT - G Type Vertical 13.0L x 3.5W x 3.5H  
2 Pole 3 Positions

■ Outline Drawing

Product No.	Package
NSS504-223N-AACG1T	900 Pcs/Reel

■ Specifications

Rating	DC6V 0.3A
Stroke	2.0±0.3 mm
Operating Force	A→B, C→B : 200 ± 100 gf B→A, B→C : 250 ± 150 gf
Contact Resistance	70mΩ max

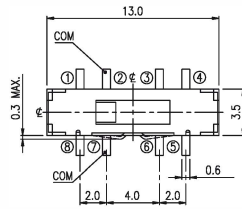

Schematic

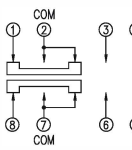

P.C.B Layout

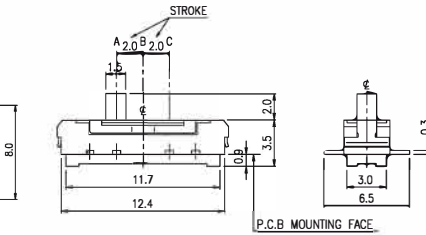
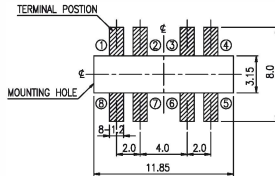

General Tolerance : ±0.2mm.

■ SMT - G Type Vertical 13.0L x 3.5W x 3.5H  
2 Pole 3 Positions

■ Outline Drawing

Product No.	Package
NSS504-223N-ABCG1T	900 Pcs/Reel

■ Specifications

Rating	DC6V 0.3A
Stroke	2.0±0.3 mm
Operating Force	A→B, C→B : 200 ± 100 gf B→A, B→C : 250 ± 150 gf
Contact Resistance	70mΩ max

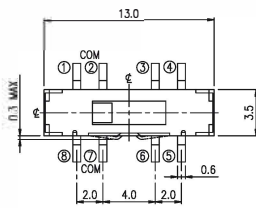

Schematic

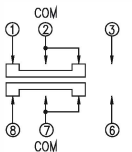

P.C.B Layout

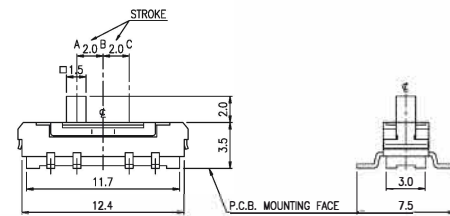
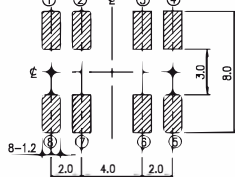

General Tolerance : ±0.2mm.

