

# NTC021 Series

■ Features

■ Lead Free ■ HF ■ RoHS

- Heavy operating force.



Rating (max)	DC12V 50mA
Contact Resistance	100mΩ max.
Insulation Resistance	DC500V-100MΩ min.
Withstand Voltage	AC250V - 1 minute
Stroke	0.15±0.1 mm

Recommended Reflow Soldering Profile

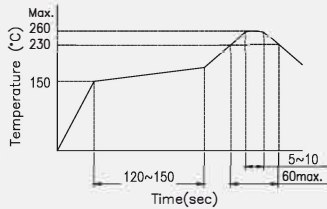

Number of Reflow Pass : 2 cycles

Recommended Manual Soldering Profile

	Temperature	Time
Manual Soldering Temperature	350 °C (max.)	3 Sec. (max.)

The solder iron and solder shall be applied at a distance of 1.91 mm to 2.54 mm from the plastic housing.

Operating Force & Durability

160 ± 50gf	500,000 cycles
450 ± 80gf	200,000 cycles

■ SMT- G Type Vertical 3.0L x 2.6W x 1.4H

Product No.	Package
NTC021-AA1G-A160TX	9,500 Pcs/Reel
NTC021-AA1G-A450T	

■ Outline Drawing

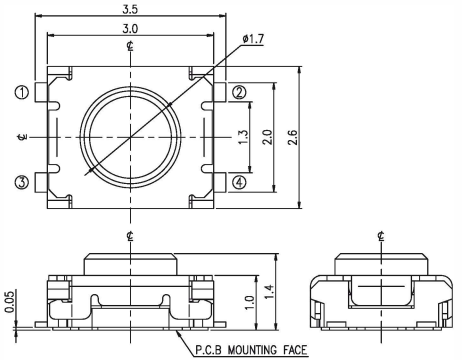

Schematic

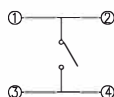

P.C.B Layout

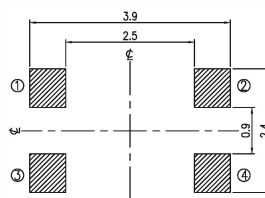

General Tolerance : ±0.2mm.